

SUTERacing
www.suterracing.com



MOTO3 PROGRAM 2012



Moto3

**Our experience: your warranty for a winning package!
The Honda engine: proven, reliable technology**

SRT Moto3 program 2012

The Moto3 strategy

Suter Racing Technology (SRT) took the decision to enter in the new Moto3 class with a high end chassis package and engine performance parts for the Honda NSF 250R engine.

The bike will be ready for the Teams in January / February, depending on Date of order. As our Moto2 machine, the new Moto3 chassis will be designed in a similar way and will carry beside a high quality aluminium main chassis & swing arm a carbon composite seat unit and other high tech technical features such as central air intake and top aerodynamics. As the weight for a Moto3 is crucial, SRT will spend a huge effort to build the lightest machine in its class.

Engine performance upgrade

SRT has the knowledge, set up and technology to make the Honda Moto3 engine performing to fight for win. We will offer you various performance steps for the Honda Engine as well a newly developed slipper clutch system.

SRT Moto3 program 2012

The Moto3 strategy

- ▣ **Spare parts track support:**
SRT will offer as in Moto2 class a spare parts track support attending all European MotoGP events as well the CEV race and test events.
- ▣ **Track support:**
SRT engineers will follow you during the events to support the Teams with set up decisions and follow up the development.
- ▣ **Shared track tests:**
SRT will organize together with all the Moto2 and Moto3 Teams running SUTER machines track tests in Europe.
- ▣ **Online spare parts order:**
Through the SRT web shop spare parts can easily ordered by mouse click! SRT deliver spare parts by very short delivery time!
- ▣ **Honda engine special developments at SRT. Power to fight for wins!**

SRT Moto3 program 2012

The Moto3 chassis package

CHASSIS PACKAGE WILL COVER FOLLOWING PARTS:

- Twin spar aluminium chassis
- Upside down swing arm and linkage system
- Chain adjusters, rear brake calliper support
- Seat unit in carbon composite support
- Fuel tank prepared to install fuel pump unit
- Airbox and air box cover included fuel lines
- Radiator with shroud, integrated catch tank, radiator hoses and clamps
- Complete wiring loom to fit data acquisition system and Dellorto ECU
- All bolts & fasteners in Titanium
- Footrest, pedals and rear master brake cylinder
- Handle bar assy, throttle twist grip and clutch lever, clutch and gas cable
- Triple clamp set, steering axle and one set head stock bearing inserts
- Air duct and dash board holder in carbon composite
- Brake lines front & complete rear brake system with brake disc
- Front & rear axles, chain sprocket and pignone
- Complete carbon composite bodywork and tail cowling
- Front and rear mudguard
- **Price: 60.000 CHF (aprox.49.000 Euro)**

SRT Moto3 program 2012

The Moto3 chassis package

CHASSIS PACKAGE WILL NEED TO BE COMPLETED WITH FOLLOWING PARTS:

- Front fork and rear shock at your decision.
- Front brake system (Master cylinder, Callipers Discs)
- Rear Brake system included in chassis package!
- Front and rear wheels at your decision, SRT supply OZ wheels at request
- Honda Fuel Pump and Voltage regulator
- Engine Honda NSF 250 with throttle body
- Dellorto ECU / Dashboard
- Complete data acquisition system

SRT will offer components as listed above at request.

As we are working closely with Öhlins, Brembo and OZ, the machines design is based on these manufacturers components. If you wish to complete your bike with other components, SRT will support you with the needed measurements and drawings that allows you to purchase components with the correct fitting dimensions etc.

SRT Moto3 program 2012

Technical features

▣ Main chassis

A twin spar aluminium chassis build from fully machined parts in combination with pressed sheet metal main beams will offer the needed stiffness values and best braking stability.

The chassis offers various adjustments in the headstock geometry and swing arm pivot position.

▣ Swing arm

A state of art upside down swing arm allows optimised stiffness values by low overall weight. The Linkage system is weight optimised and different link ratios will be available.

▣ Wiring loom

As on our Moto2 machine, the wiring loom is completed with deutsch connectors and all the wiring for the data acquisition is included.

SRT Moto3 program 2012

Technical features

▣ Aerodynamics

SRT regularly undertakes wind tunnel tests to optimise the aerodynamics of their machinery. CFD calculations helps to find new aspects for better airflow, in the wind tunnel all details can be proved and further redefine. Best Speed values with our Moto2 machine proofs the strategy.

The air intake and the airbox was undergoing a deep study to create maximal ram air effect which leads to better engine performance-

SRT found a way to create a very efficient cooling system which leads to minimal drag losses by best cooling performance.

▣ Rider ergonomics

The rider ergonomics on the bike is one of the most crucial points for a racing motorcycle. Especially on a small machine as the Moto3 the rider must feel comfortable in “top speed” position.

SRT Moto3 program 2012

Technical features

▣ Fuel tank

To keep always the best machine balance, the fuel is located at the centre of gravity thus the balance will not change with different fuel load. The fuel tank will have an integrated fuel pump with pressure regulator and quick fuel connector. Fuel tank will be imbedded in the carbon seat unit and all is fitted to the main chassis with four bolts. Easy replacement of the whole part in case of crash damage.

▣ Exhaust

SRT took the decision to run a seat unit exhaust system in order to create maximum performance and take the full advantage of the Honda engines rear headed exhaust port.

SRT Moto3 program 2012

SUTER MOTO3 Champions technology

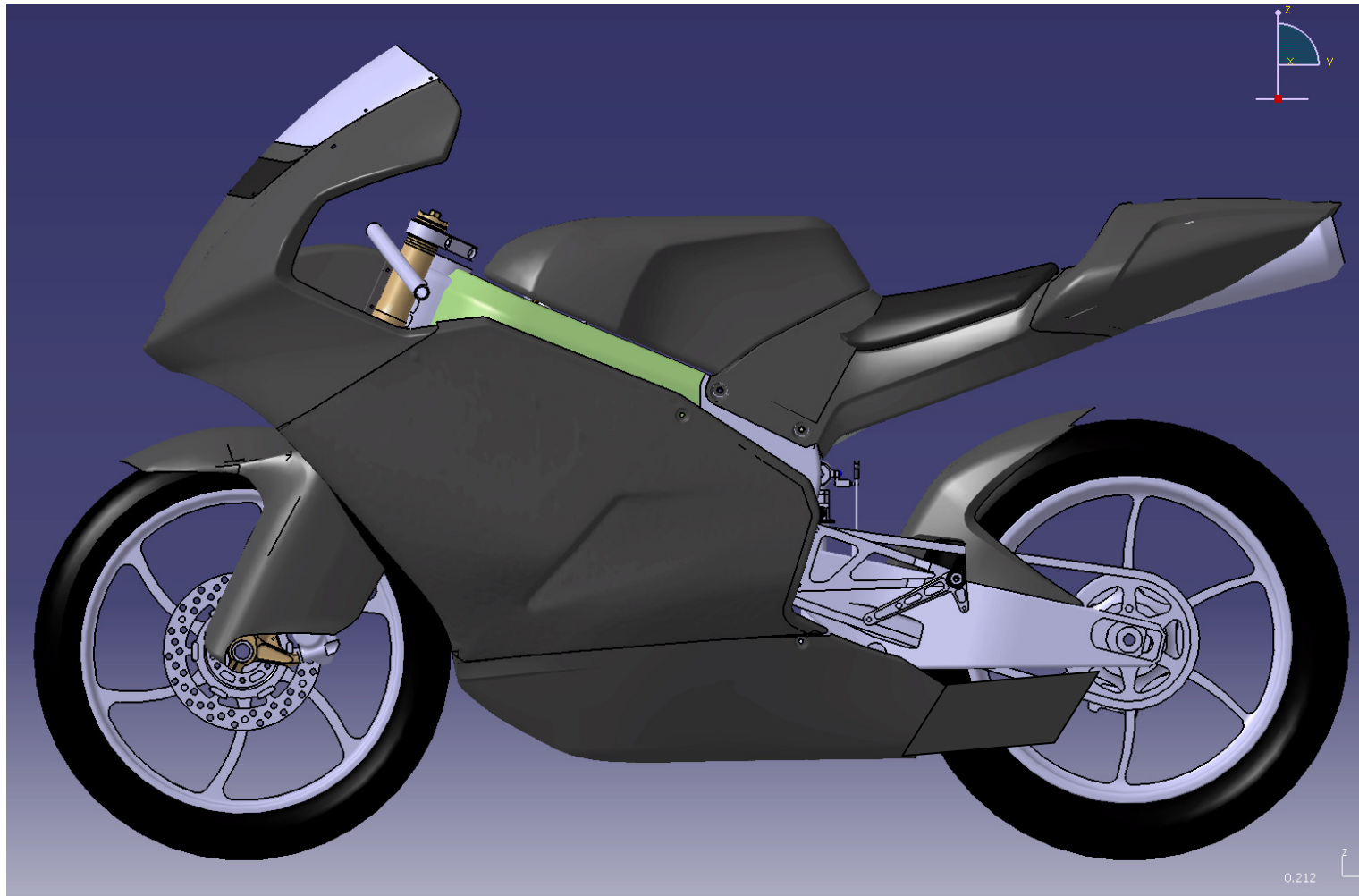

SRT Moto3 program 2012

SUTER MOTO3 Champions technology

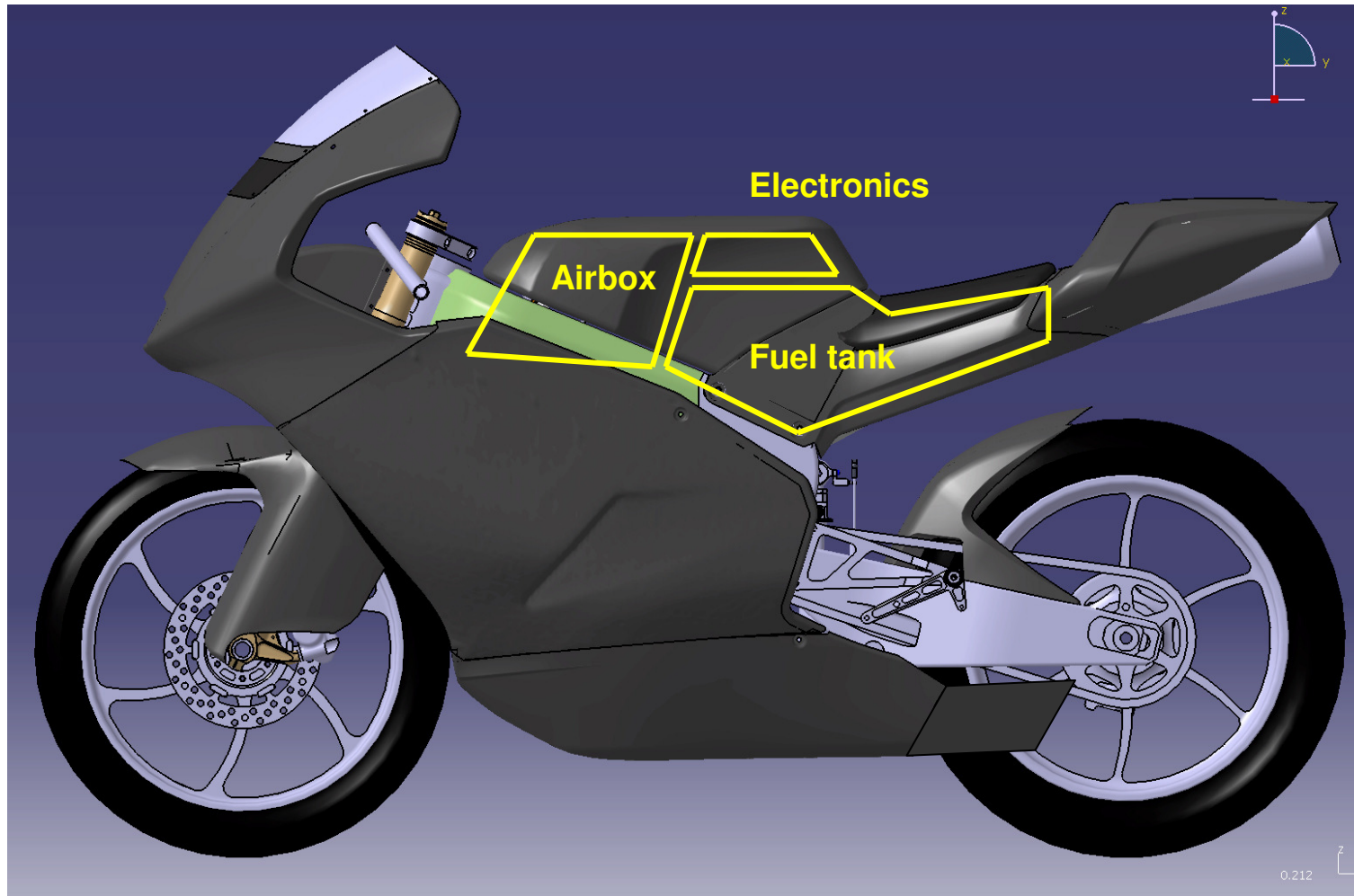

SRT Moto3 program 2012

SUTER MOTO3 Champions technology

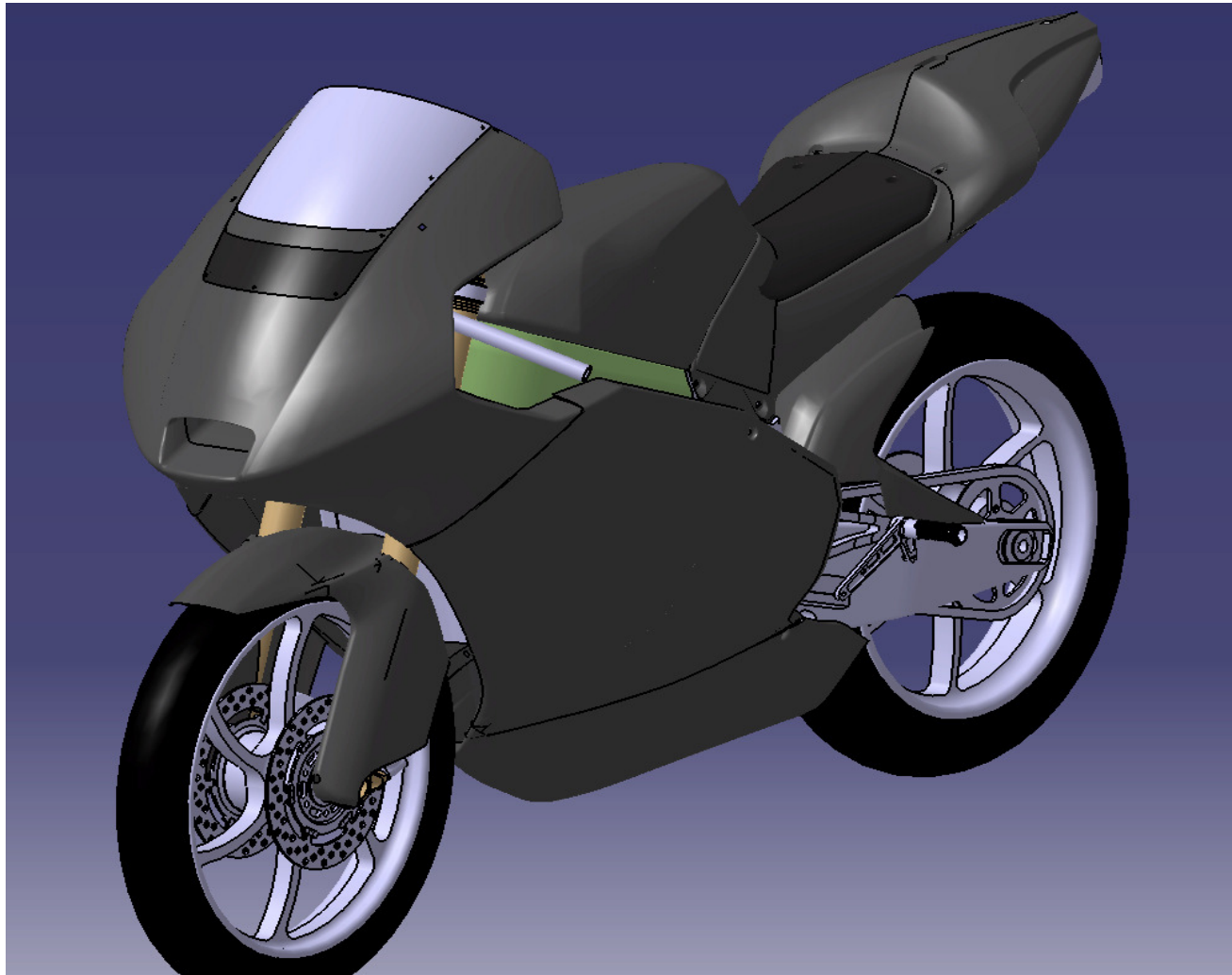

SRT Moto3 program 2012

SUTER MOTO3 Champions technology

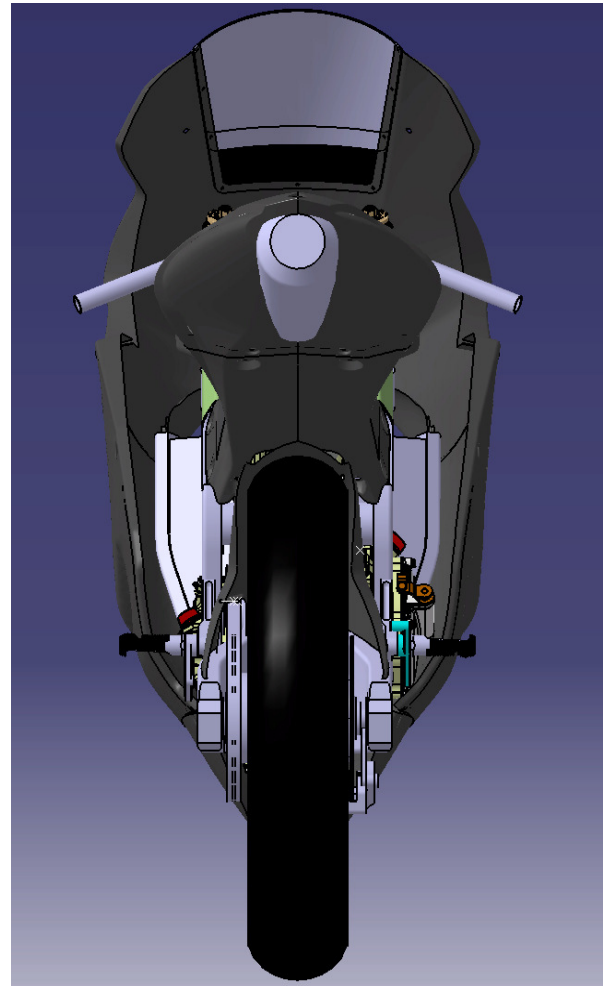

SRT Moto3 program 2012

SUTER MOTO3 Champions technology

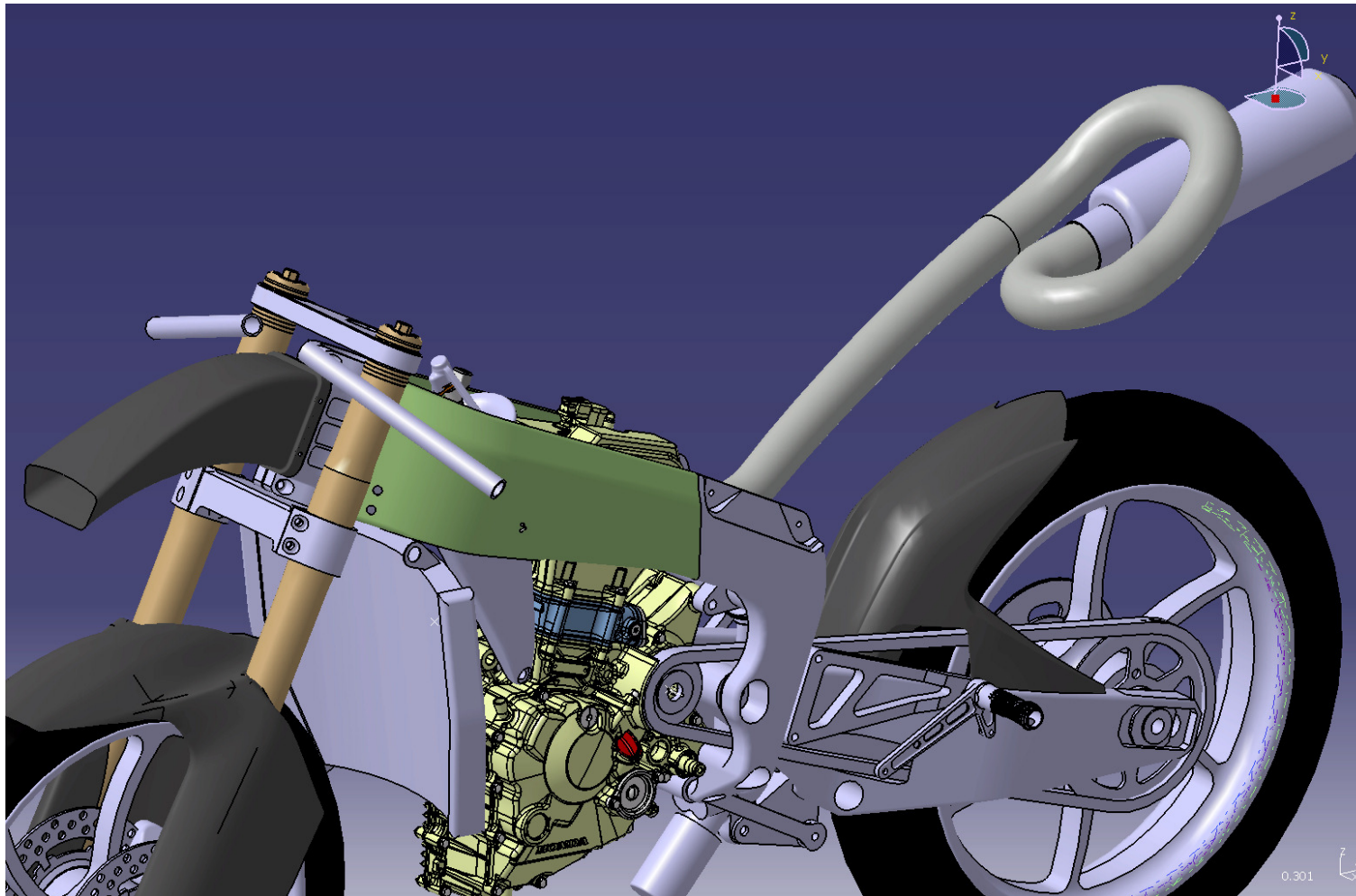

SRT Moto3 program 2012

The MOCAL chassis software

- ❑ Suter Racing offers a specific chassis calculation program
- ❑ All parameters and set up geometries are in the database
- ❑ Easy understanding of bike set up and changes
- ❑ Calculates Geometry, centre of gravity, wheel base, angles and weight distribution
- ❑ All inclusive, 3500CHF (special offer for SUTER users only)

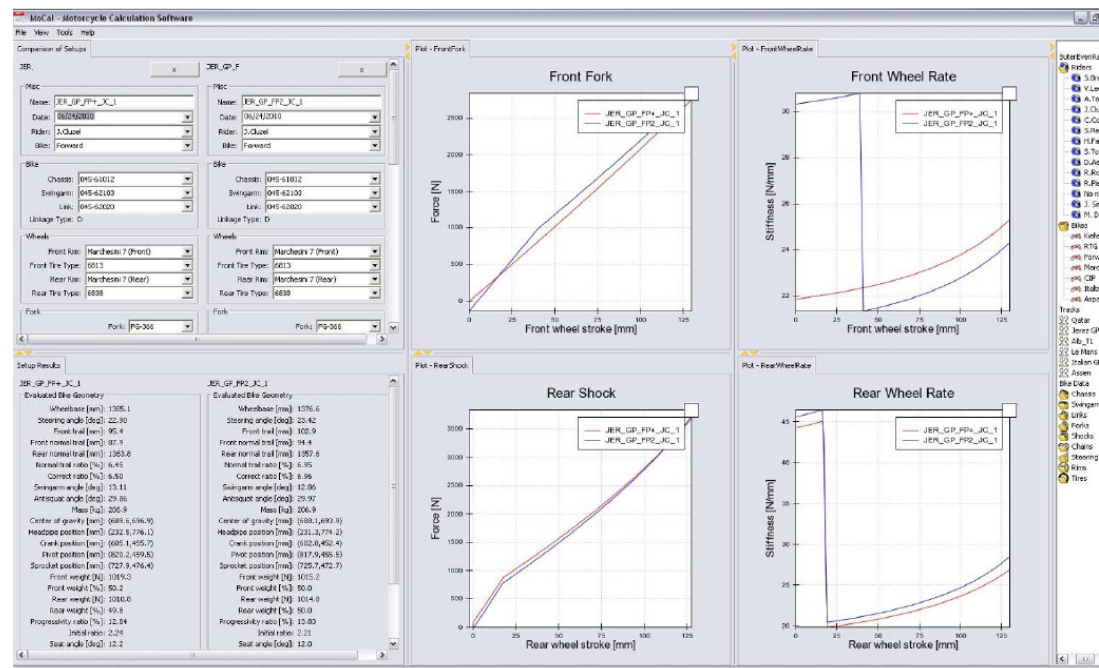

Please ask for your individual offer:

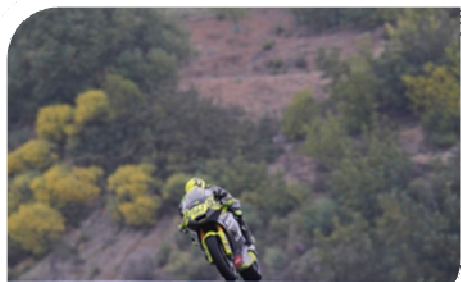

Suter Racing Technology AG
Mettlenstrasse 3
8488 Turbenthal – Swiss
Sales & Marketing:
Andreas Leuthe
Mail: a.leuthe@suterracing.ch
Phone: +41-79-848 39 31

